

Patient Slings

DEALER: This manual must be given to the user of the product.

USER: BEFORE using this product, read this manual and save for future reference.

For more information regarding
Invacare products, parts, and services,
please visit www.invacare.com



Yes, you can.

⚠ WARNING

DO NOT USE THIS PRODUCT OR ANY AVAILABLE OPTIONAL EQUIPMENT WITHOUT FIRST COMPLETELY READING AND UNDERSTANDING THESE INSTRUCTIONS AND ANY ADDITIONAL INSTRUCTIONAL MATERIAL SUCH AS OWNER'S MANUALS, SERVICE MANUALS OR INSTRUCTION SHEETS SUPPLIED WITH THIS PRODUCT OR OPTIONAL EQUIPMENT. IF YOU ARE UNABLE TO UNDERSTAND THE WARNINGS, CAUTIONS OR INSTRUCTIONS, CONTACT A HEALTHCARE PROFESSIONAL, DEALER OR TECHNICAL PERSONNEL BEFORE ATTEMPTING TO USE THIS EQUIPMENT - OTHERWISE, INJURY OR DAMAGE MAY OCCUR.

⚠ ACCESSORIES WARNING

Invacare products are specifically designed and manufactured for use in conjunction with Invacare accessories. Accessories designed by other manufacturers have not been tested by Invacare and are not recommended for use with Invacare products.

NOTE: Updated versions of this manual are available on www.invacare.com.

TABLE OF CONTENTS

SPECIAL NOTES	4
SECTION 1—GENERAL GUIDELINES	5
Using the Sling.....	5
Care	6
SECTION 2—SLING STYLES	7
Standard Series Style Slings and Kits.....	7
One-Piece Style Slings	7
SECTION 3—USING THE STANDARD STYLE SLING	8
Introduction.....	8
Care	8
Removing/Installing the Metal Support Bars in the Standard Style Sling.....	8
Positioning the Standard Style Sling.....	9
Attaching the Chains or Straps to the Standard Style Sling.....	10
Attaching the Standard Style Sling to the Patient Lift	11
SECTION 4—USING FULL BODY, COMFORT AND HEAVY-DUTY ONE-PIECE STYLE SLINGS	12
Positioning the Sling.....	12
Attaching the One-Piece Style Sling to the Patient Lift	14
SECTION 5—USING DIVIDED LEG, UNIVERSAL HIGH, EASY-FIT, TOILETING, DRESS TOILETING HIGH AND CRADLE ONE-PIECE STYLE SLINGS	15
Introduction.....	15
Positioning the Sling.....	15
Attaching the One-Piece Style Sling to the Patient Lift	17
Slings Using the Cradle Attachment.....	17
SECTION 6—USING STANDING, STAND ASSIST, TRANSPORT AND TRANSFER ONE-PIECE STYLE SLINGS	18
Positioning the Sling Around the Patient	18
Standing Sling.....	18
Transport Sling or Transfer Sling	19
Attaching the Sling to the Stand Up Lift.....	20
Standing Sling.....	20
Transport Sling or Transfer Sling	22
LIMITED WARRANTY	24

SPECIAL NOTES

Signal words are used in this manual and apply to hazards or unsafe practices which could result in personal injury or property damage. Refer to the table below for definitions of the signal words.

SIGNAL WORD	MEANING
DANGER	Danger indicates an imminently hazardous situation which, if not avoided, will result in death or serious injury.
WARNING	Warning indicates a potentially hazardous situation which, if not avoided, could result in death or serious injury.
CAUTION	Caution indicates a potentially hazardous situation which, if not avoided, may result in property damage or minor injury or both.

NOTICE

THE INFORMATION CONTAINED IN THIS DOCUMENT IS SUBJECT TO CHANGE WITHOUT NOTICE.

SECTION I—GENERAL GUIDELINES

⚠ WARNING

SECTION I - GENERAL GUIDELINES contains important information for the safe operation and use of this product.

⚠ WARNING

DO NOT move a person suspended in a sling any distance. The Invacare patient lift or the sling are **NOT** transport devices. They are intended to transfer an individual from one resting surface to another (such as a bed to a wheelchair). Otherwise, injury or damage may occur.

Check all parts for shipping damage before using. In case of damage, **DO NOT** use the equipment. Contact the dealer for further instructions.

DO NOT attempt any transfer without approval of the patient's physician, nurse or medical assistant. Thoroughly read the instructions in this owner's manual, observe a trained team of experts perform the lifting procedures and then perform the entire lift procedure several times with proper supervision and a capable individual acting as a patient.

Although Invacare recommends that two assistants be used for all lifting preparation, transferring from and transferring to procedures, our equipment will permit proper operation by one assistant. The use of one assistant is based on the evaluation of the health care professional for each individual case. Bed rails may be used to minimize patient movement during sling positioning.

ALWAYS keep hands and fingers clear of moving parts to avoid injury.

DO NOT exceed maximum weight limitation of the patient lift. These weights will vary from 350 to 600 lbs. depending on the type of patient lift purchased. For maximum weight limitation, refer to the Typical Product Parameters section in the patient lift manual or contact customer service.

Invacare slings are made specifically for use with Invacare lifts. For the safety of the patient, **DO NOT** intermix slings and lifts of different manufacturers.

Using the Sling

Use an Invacare approved sling that is recommended by the individual's doctor, nurse or medical assistant for the comfort and safety of the individual being lifted.

Standing Slings - Individuals that use the standing sling **MUST** be able to support the majority of their own weight, otherwise injury can occur. Before lifting the patient, make sure the bottom edge of the standing sling is positioned on the lower back of the patient and the patient's arms are outside the standing sling. The belt **MUST** be snug, but comfortable on the patient, otherwise the patient can slide out of the sling during transfer, possibly causing injury.

Transport/Transfer Slings - Before lifting the patient, make sure the bottom edge of the transfer sling is at the base of the spine and the patient's arms are outside the transfer sling. **DO NOT** raise the patient to a full standing position while using the transfer sling, otherwise injury may occur.

The Jasmine Patient Lift can be used with the standard swivel bar or an optional cradle attachment. The tilting cradle attachment enables a single caregiver to more easily position a patient in an upright and seated position.

DO NOT use any kind of material (such as a plastic back incontinence pad or seating cushion) between the patient and sling material that may cause the patient to slide out of the sling during transferring.

After each laundering (in accordance with instructions on the sling), inspect sling(s) for wear, tears, and loose stitching.

Bleached, torn, cut, frayed, or broken slings are unsafe and could result in injury. Discard immediately.

DO NOT alter slings.

When connecting slings equipped with color coded straps to the patient lift, the shortest of the straps **MUST** be at the back of the patient for support. Using the long section will leave little or no support for the patient's back. The loops of the sling are color coded and can be used to place the patient in various positions. The colors make it easy to connect both sides of the sling equally. Make sure that there is sufficient head support when lifting a patient.

Care

*NOTE: Laundering should always be done with dark colors. The sling should be washed regularly in a water temperature not to exceed 180°F (82°C). **DO NOT** bleach. Air dry or dry at low temperature. Inspect with each use. Refer to tagged washing instructions on the sling.*

⚠ WARNING

After each laundering (in accordance with instructions on the sling), inspect sling(s) for wear, tears, and loose stitching. Bleached, torn, cut, frayed, or broken slings are unsafe and could result in injury. Discard immediately.

SECTION 2—SLING STYLES

Standard Series Style Slings and Kits

Invacare's standard series slings are designed specifically for use with the 9805/9805P lifts. The standard style sling attaches to the lift with either adjustable straps or chains (interchangeable).

STANDARD SERIES SLING DESCRIPTION	CAN ONLY BE USED WITH ...
Polyester Sling	9805/9805P Lifts
Polyester Sling With Commode Opening	
Polyester Mesh Sling	
Polyester Mesh Sling With Commode Opening	
Strap Kit	
Chain Kit	

One-Piece Style Slings

Invacare's one-piece sling attaches to the patient lift with color coded sling loops that provide an easy way to position the patient. There are no additional strap or chain kits required for use with the one-piece sling styles.

ONE-PIECE FABRIC SLING DESCRIPTION	CAN ONLY BE USED WITH ...
Full Body Sling with or without Commode Opening	Jasmine, Reliant 450, Reliant 600 Lifts and 9805 Lifts (on the large hooks of the Swivel Bar)
Comfort Sling with or without Commode Opening	
Divided Leg Sling	
Universal High Sling	
Easy Fit Sling	
Toileting Sling	
Dress High Toileting Sling	Reliant 450, Reliant 600 and Jasmine Lifts
Heavy-Duty Sling with or without Commode Opening	
Cradle Sling	Jasmine Lift equipped with optional Cradle Attachment
Standing Sling	Reliant 350, Reliant 440, Get-U-Up™ and Roze Lifts
Stand Assist Sling	
Transport Sling	
Transfer Sling	

SECTION 3—USING THE STANDARD STYLE SLING

Introduction

The hardware used with the standard sling includes four metal support bars. The support bars insert into the pockets at the edge of the fabric. The pocket that holds the metal bar has an opening in the center. The pocket is sewn closed on one end and has an open-end with a strap on the other.

Care

Remove the four metal support bars before laundering the standard style sling. The metal support bars **MUST** be replaced before the sling can be used for patient lifting.

Removing/Installing the Metal Support Bars in the Standard Style Sling

NOTE: To remove the metal support bar, reverse this procedure.

NOTE: For this procedure, refer to FIGURE 3.1.

1. To insert the metal support bar, pull the strap and insert the metal bar into the opening in the sling pocket. Refer to Detail "A".
2. Push the metal support bar through until the mounting hole clears the center opening of the sling pocket. Refer to Details "B" and "C".
3. Once the opposite end of the bar is inside the sewn pocket, push the strap over the metal support bar. Refer to Detail "D".

*NOTE: The hole in the metal bar **MUST** be in the center of the pocket opening.*

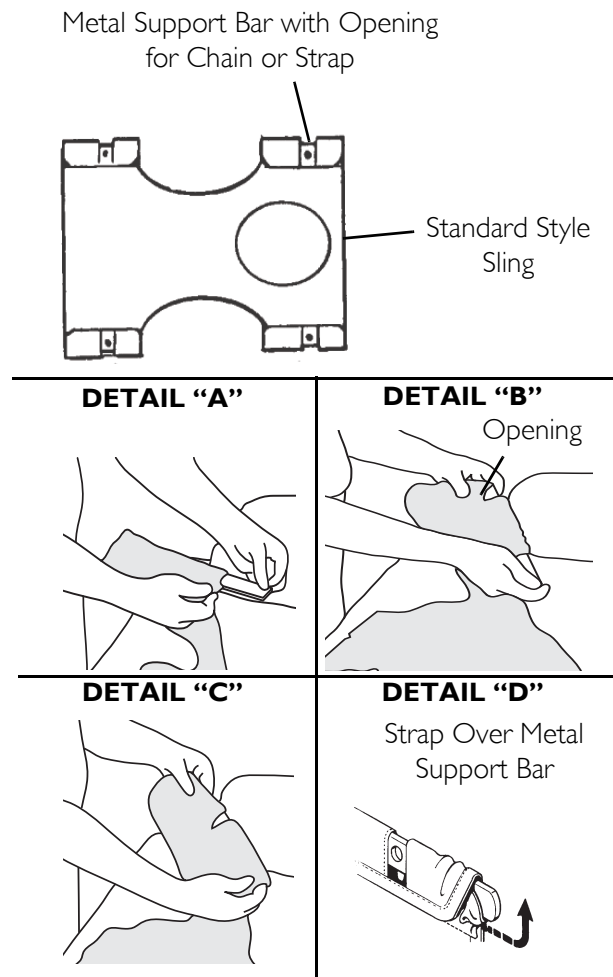

FIGURE 3.1 Removing/Installing the Metal Support Bars in the Standard Style Sling

Positioning the Standard Style Sling

NOTE: For this procedure, refer to FIGURE 3.2.

NOTE: Use the following method to easily move the patient and avoid strain to yourself.

1. With an attendant on each side of the bed and up against the mattress, the attendant on the right-hand side of the bed will elevate the left knee and position his/her left-hand on the elevated knee and his/her right-hand under the patient's left shoulder, slowly push on the knee and assist with a slight lift of the shoulder and the patient will easily roll onto their side. Refer to Detail "A".
2. Put the standard style sling onto the mattress.

NOTE: The upper edge of the back section should be positioned slightly above the armpit level and the lower edge of the seat section positioned a few inches above the back of the patient's knees Refer to Detail "A".

3. Roll the patient onto his/her back.
4. Pull the sling across the mattress until smooth.

NOTE: The patient should be approximately centered on the sling section. Refer to Detail "B".

NOTE: The sling is now ready to be attached to the chain or strap. Refer to Attaching the Chains or Straps to the Standard Style Sling on page 10.

DETAIL "A"



DETAIL "B"



FIGURE 3.2 Positioning the Standard Style Sling

Attaching the Chains or Straps to the Standard Style Sling

NOTE: For this procedure, refer to FIGURE 3.3.

NOTE: Each sling will work with either a pair of chain assemblies or a pair of strap assemblies.

MODEL NUMBERS	DESCRIPTIONS
9070	Strap Kit
9071	Chain Kit

CAUTION

When using either the chains or straps to connect the sling to the patient lift, the shortest of the two sections of the chains or straps **MUST be attached to the back section of the sling. Using the long section will leave little or no support for the patient's back.**

1. With the patient laying on his/her back and positioned properly in the sling, lay the chains or straps on the bed next to the sling. Refer to Detail "A".
2. The short section of chain or strap will be placed parallel to the patient's back. This will position the longer section of chain or strap from the waist to the mid section of the thigh.
3. The "S" hooks on the ends of the chains or straps are inserted into the metal support bar of the sling.
4. The "S" hook **MUST** be inserted through the hole in the support bar with the open end facing away from the patient. Refer to Detail "C".
5. Position the lift for use. Refer to [Attaching the Standard Style Sling to the Patient Lift](#) on page 11.

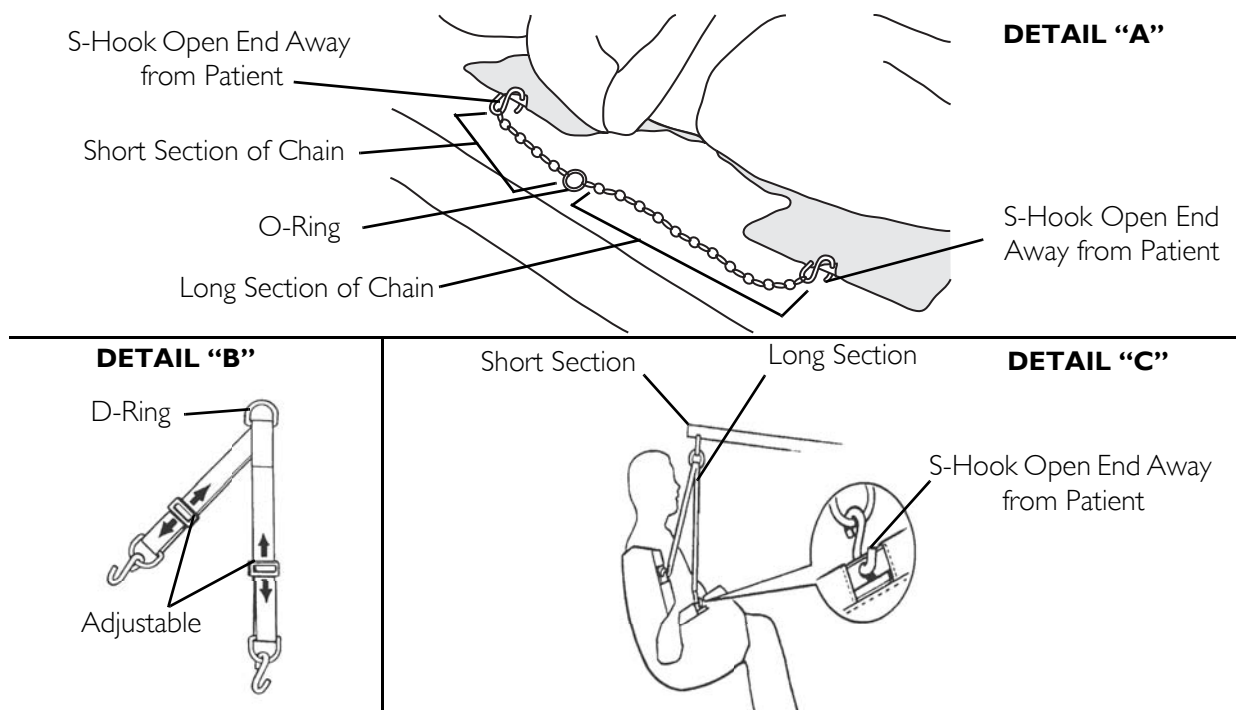

FIGURE 3.3 Attaching the Chains or Straps to the Standard Style Sling

Attaching the Standard Style Sling to the Patient Lift

NOTE: For this procedure, refer to FIGURE 3.4.

1. The D-ring (strap) or O-ring (chain) is the suggested location to attach the swivel bar, however, by changing to different links or adjusting the strap, you can reposition the patient into a reclining or more upright position.

⚠ WARNING

When changing to different lengths, DO NOT disconnect the O-rings of the chains from the swivel bar. Position BOTH the O-rings and additional chain link onto the hooks of the swivel bar.

NOTE: The straps can be simply adjusted to achieve the same effect.

2. With the sling positioned under the patient and the support bars in place, move the lift into position to attach the sling hardware to the swivel bar.
3. Refer to Lifting the Patient in the Patient Lift Owner's Manual.

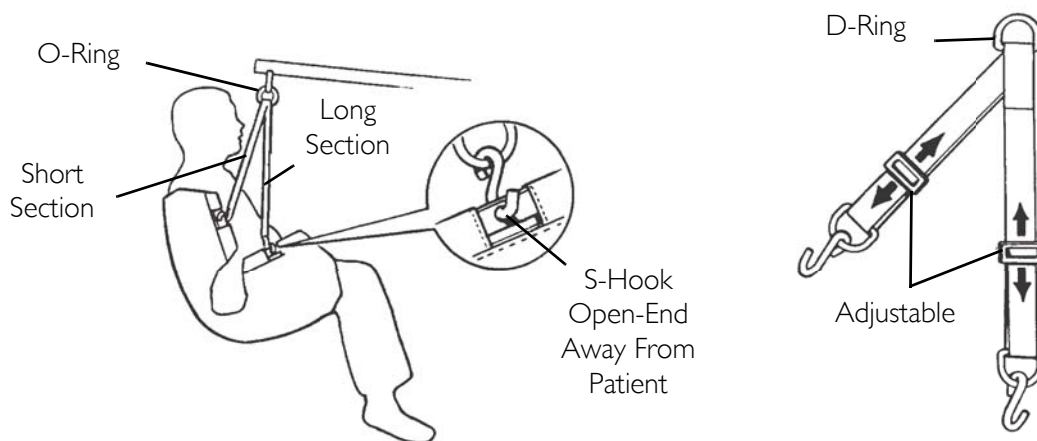

FIGURE 3.4 Attaching the Standard Style Sling to the Patient Lift

SECTION 4—USING FULL BODY, COMFORT AND HEAVY-DUTY ONE-PIECE STYLE SLINGS

Positioning the Sling

NOTE: For this procedure, refer to FIGURE 4.1 and FIGURE 4.2 on page 13.

NOTE: Use the following method to easily move the patient and avoid strain to yourself.

1. Position the patient in the center of the bed and laying flat on his/her back.
2. Fold the sling in half (length-wise) and place the sling beside the patient. Refer to Detail “A”.

NOTE: The closed-end or commode opening of the sling with positioning handle should be facing the patient when folded.

NOTE: The top edge of the sling fabric should be slightly above the patient’s head. The bottom edge of the sling fabric should then be a few inches above the back of the patient’s knees.

3. With one assistant holding the patient, the second assistant pushes the folded sling under the patient without rolling him/her over. Refer to Detail “B”.

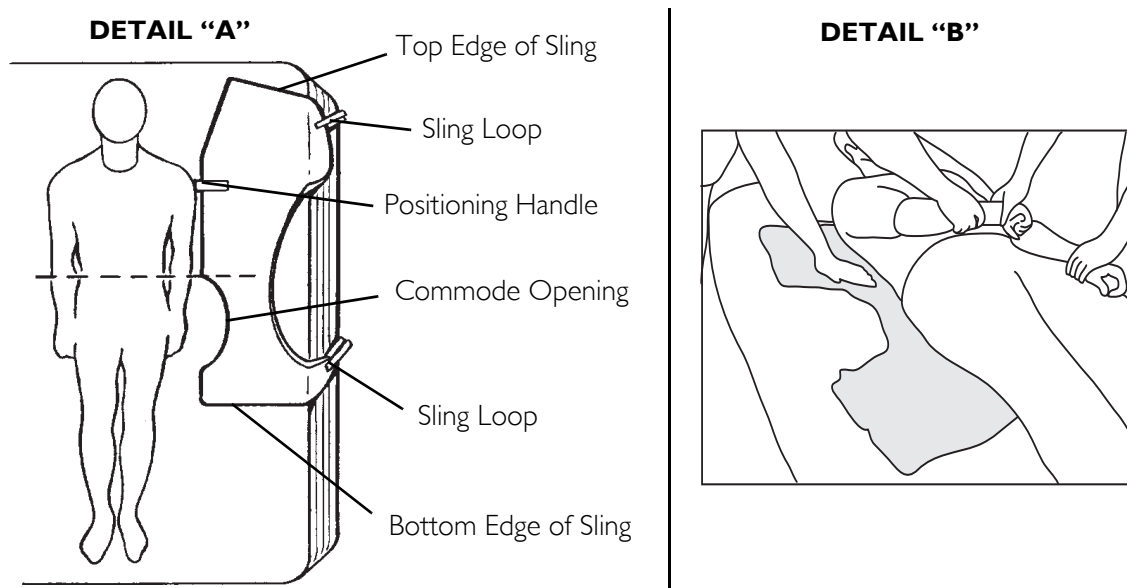

FIGURE 4.1 Positioning the Sling

4. With an assistant on each side of the bed and up against the mattress, the assistant on the left-hand side of the bed will position his/her right-hand on the elevated knee and his/her left-hand under the patient’s right shoulder, slowly push on the knee and assist with a slight lift of the shoulder. The patient will easily roll onto his/her side. Refer to Detail “A”.

5. With the patient on their side, push the fabrics of the seat and back gently under them. Refer to Detail “B”.

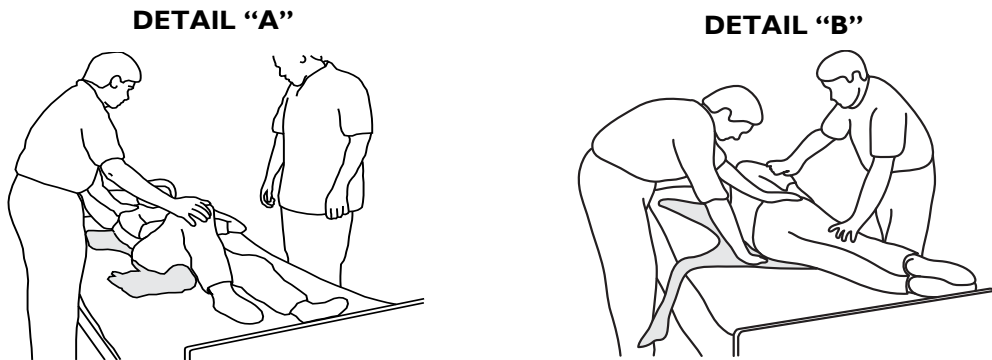

FIGURE 4.2 Rolling Patient Onto His/Her Side

NOTE: The patient’s head should be positioned in the headrest just below the top edge for maximum comfort and the lower edge of the seat section positioned a few inches above the back of the patient’s knees.

6. Roll the patient on to his/her back.

NOTE: Assistants will reverse roles.

7. After the patient has been positioned once again on his/her back, you now need to roll the patient to their right-side (facing the assistant on the left).
8. With an assistant on each side of the bed and up against the mattress, the assistant on the right-hand side of the bed will elevate the left knee and position his/her left-hand on the elevated knee and his/her right-hand under the patient’s left shoulder, slowly push on the knee and assist with a slight lift of the shoulder and the patient will easily roll onto their side. Refer to Detail “A”.
9. Pull the fabrics of the seat and back across the mattress until they are smooth.
10. Roll the patient onto their back and they should be approximately centered on the sling.
11. Position the lift for use. Refer to Attaching the One-Piece Style Sling to the Patient Lift.

Attaching the One-Piece Style Sling to the Patient Lift

NOTE: For this procedure, refer to FIGURE 4.3.

1. Place the straps of the sling over hooks of the swivel bar. Match the corresponding colors on each side of the sling for an even lift of the patient.

CAUTION

When connecting sling to the patient lift, the shortest of the straps **MUST be at the back of patient for support. Using long section will leave little or no support for patient's back. The loops of the sling are color coded and can be used to place patient in various positions. The colors make it easy to connect both sides of the sling equally. Make sure that there is sufficient head support when lifting a patient.**

2. Refer to the Lifting the Patient in the Patient Lift Owner's Manual.

*NOTE: Invacare Lift Swivel Bars have three hookup points per side. The middle hookup is **ONLY** used for slings that have three sets of straps per side or slings that use chains or adjustable straps.*

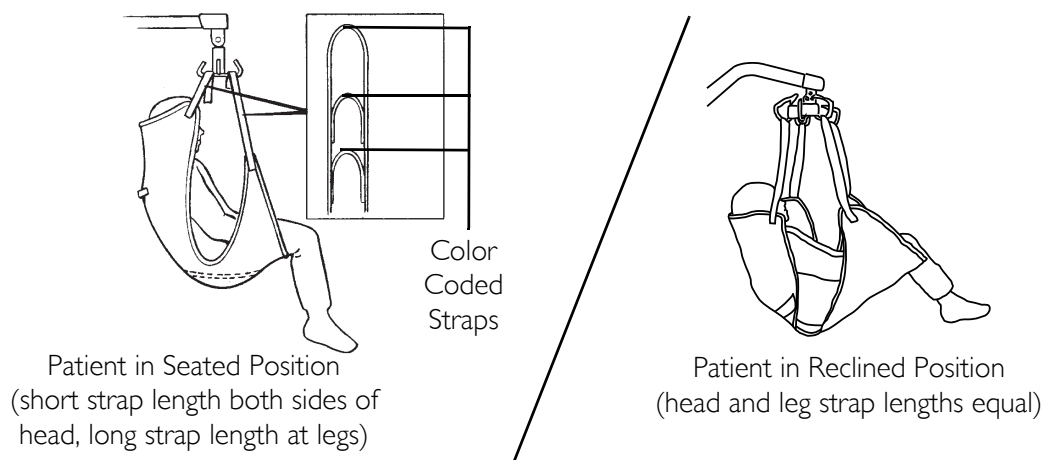

FIGURE 4.3 Attaching the One-Piece Style Sling to the Patient Lift

SECTION 5—USING DIVIDED LEG, UNIVERSAL HIGH, EASY-FIT, TOILETING, DRESS TOILETING HIGH AND CRADLE ONE-PIECE STYLE SLINGS

Introduction

Divided Leg, Universal High, Easy Fit, Toileting, Dress Toileting High and Cradle Sling styles may be used for patients on which sling removal is more difficult. Support ranges from upper back to beneath the thighs. These slings can be positioned with the patient seated or lying flat.

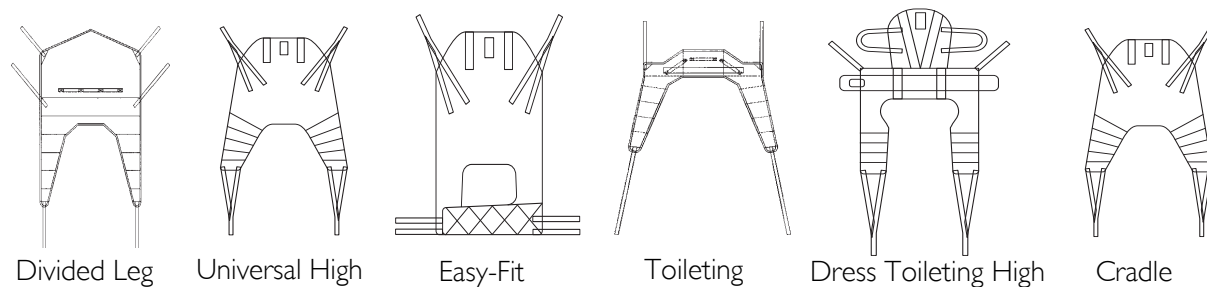

FIGURE 5.1 Sling Styles

Positioning the Sling

NOTE: For this procedure, refer to FIGURE 5.2 and FIGURE 5.3 on page 16.

NOTE: Use the following method to easily move the patient and avoid strain to yourself.

⚠ WARNING

If the patient is in a wheelchair, secure the wheel locks in place to prevent the wheelchair from moving forward or backwards.

1. Lock both rear wheel locks on the wheelchair.

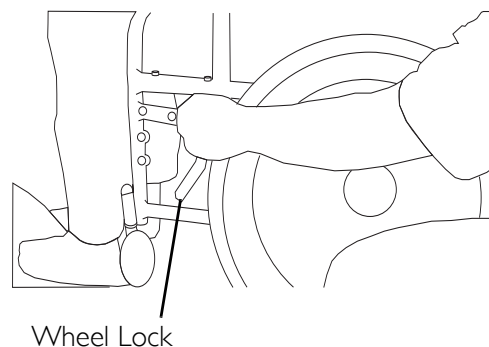

FIGURE 5.2 Wheel Lock

SECTION 5—USING DIVIDED LEG, UNIVERSAL HIGH, EASY-FIT, TOILETING, DRESS TOILETING HIGH AND CRADLE ONE-PIECE STYLE SLINGS

- With the patient sitting in a wheelchair one assistant in front of the wheelchair and the other assistant in the back of the wheelchair, lean the patient forward. Refer to Detail "A".

NOTE: The front assistant will be supporting the weight of the patient.

- Place the sling behind the patient (with "grab handle" on the outside) and bring the flaps out alongside the patient's legs. Refer to Detail "B".

NOTE: Toileting slings have a waist buckle which helps hold the sling in place during positioning.

NOTE: For the Divided Leg, Universal High, Easy-Fit, Dress Toileting High and Cradle sling: the back of the sling should be parallel to the patient's upper arms and be positioned between the top of the patient's head and the base of the spine.

NOTE: For the Toileting Sling: the back of the sling should be parallel to the patient's upper arms and be positioned between the top of the patient's midback and the base of the spine.

- With the back of the sling positioned properly, push the bottom of the back section to the seat.
- Lean the patient back into the wheelchair with the assistant in the rear supporting his/her weight.
- Lift the patient's legs (one at a time) and reach under the patient's leg to pull the front of the sling until it is behind the patient's knees (about 3 inches). The back of the sling should remain in position. Refer to Details "C" to "F".

NOTE: The straps may be around, crossed between or underneath the patient's legs. Refer to Detail "G".

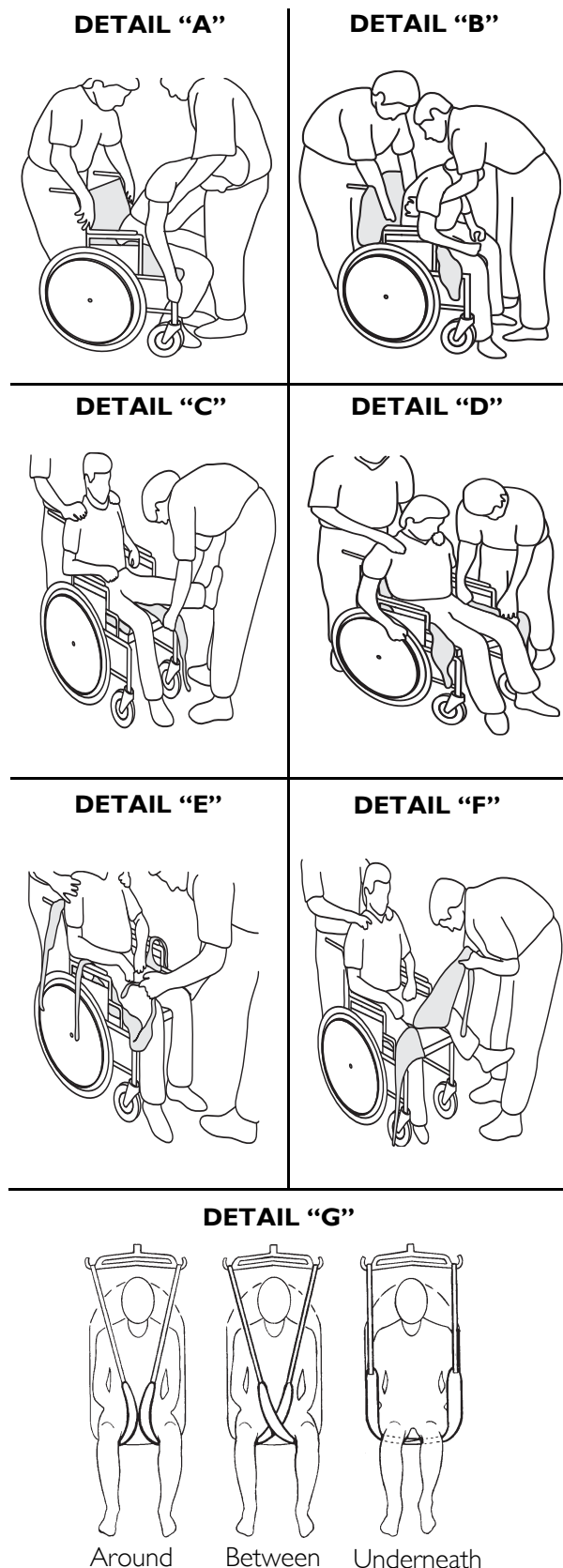

FIGURE 5.3 Positioning the Sling

Attaching the One-Piece Style Sling to the Patient Lift

NOTE: For this procedure, refer to FIGURE 5.4.

1. Place the straps of the sling over hooks of the swivel bar. Match the corresponding colors on each side of the sling for an even lift of the patient.

CAUTION

When connecting sling to the patient lift, the shortest of the straps **MUST** be at the back of patient for support. Using long section will leave little or no support for patient's back. The loops of the sling are color coded and can be used to place patient in various positions. The colors make it easy to connect both sides of the sling equally. Make sure that there is sufficient head support when lifting a patient.

2. Refer to the Lifting the Patient in the Patient Lift Owner's Manual.

NOTE: Invacare Lift Swivel Bars have three hookup points per side. The middle hookup is **ONLY** used for slings that have three sets of straps per side or slings that use chains or adjustable straps.

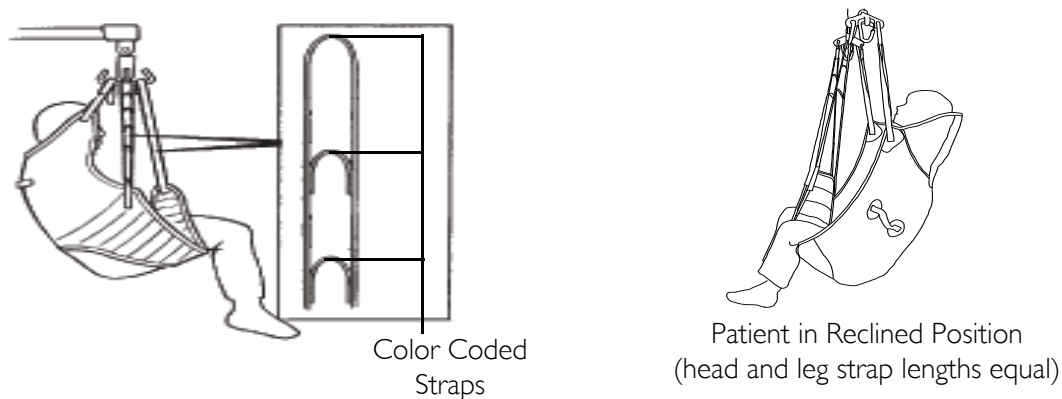

FIGURE 5.4 Attaching Slings to Lift - Slings Using Color Coded Straps

Slings Using the Cradle Attachment

The cradle sling has four straps that attach over pegs on the cradle attachment.

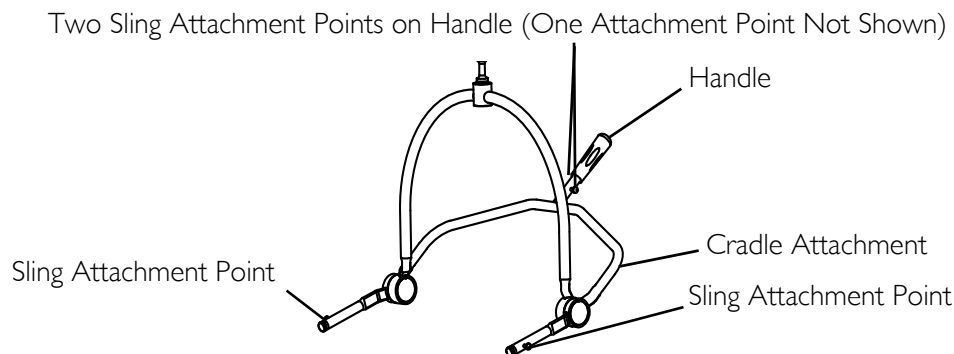

FIGURE 5.5 Attaching Slings to Lift - Slings Using the Cradle Attachment

SECTION 6—USING STANDING, STAND ASSIST, TRANSPORT AND TRANSFER ONE-PIECE STYLE SLINGS

Positioning the Sling Around the Patient

Standing Sling

⚠ WARNING

Individuals that use the Standing Sling **MUST** be able to support the majority of their own weight, otherwise injury can occur.

DO NOT use the standing sling in combination with the stand up lift as a transport device. It is intended to transfer an individual from one resting surface to another (such as a bed to a wheelchair). Moving a person using the standing sling in combination with the stand up lift over any distance is not recommended.

DO NOT use any kind of material (such as a plastic back incontinence pad or seating cushion) between the patient and sling material that may cause the patient to slide out of the sling during transferring.

Before lifting the patient, make sure the bottom edge of the standing sling is positioned on the lower back of the patient and the patient's arms are outside the standing sling.

NOTE: For this procedure, refer to FIGURE 6.1 on page 19.

1. Position the standing sling around the patient's torso just below the shoulder blades and under the arms. Refer to Detail "A".

NOTE: Make sure the bottom edge of the sling is on the lower back and the patient's arms are outside the standing sling.

NOTE: The belt should be towards the patient with the labels at the bottom of the standing sling.

2. Secure the standing sling to the patient by buckling the belt. Refer to Detail "B".
-

⚠ WARNING

The belt MUST be snug, but comfortable on the patient, otherwise the patient can slide out of the sling during transfer, possibly causing injury.

3. Adjust the belt for a snug, but comfortable fit. Refer to Detail "C".
 4. Attach the standing sling to the stand up lift. Refer to Attaching the Sling to the Stand Up Lift on page 20.
-

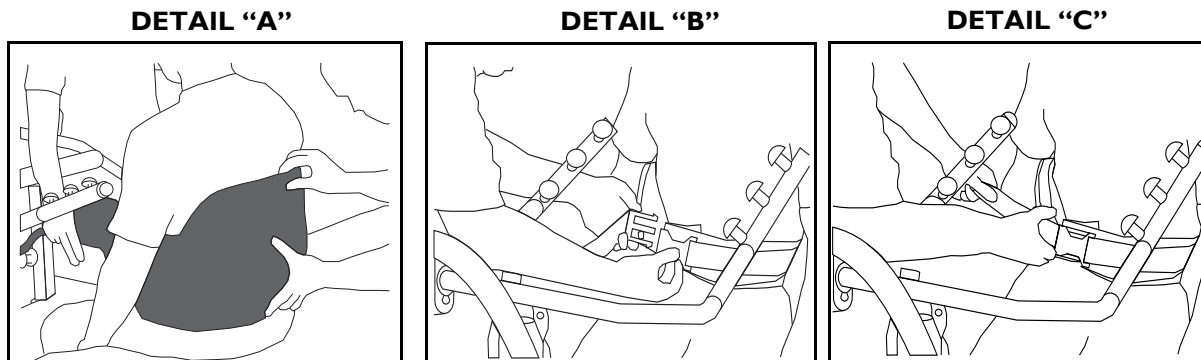

FIGURE 6.1 Positioning the Slings Around the Patient - Standing and Stand Assist Slings

Transport Sling or Transfer Sling

⚠ WARNING

DO NOT raise the patient to a full standing position while using the transport or transfer sling, otherwise injury can occur.

DO NOT use any kind of material (such as a plastic back incontinence pad or seating cushion) between the patient and sling material that may cause the patient to slide out of the sling during transferring.

Before lifting the patient, make sure the bottom edge of the transport or transfer sling is at the base of the spine and the patient's arms are outside the transport or transfer sling.

NOTE: For this procedure, refer to FIGURE 6.2 on page 20.

1. Position the transport/transfer sling behind the patient. Make sure the bottom edge of the sling is at the base of the spine. Refer to Detail "A".

NOTE: The labels on the transport/transfer sling should be up and facing away from the patient.

2. Lift up one of the patient's legs and position the thigh support under the leg. Refer to Detail "B".
3. Repeat STEP 2 for the opposite thigh support.
4. Pull the thigh support of the sling under each thigh of the patient until the thigh supports reach completely around the thighs of the patient.

NOTE: Make sure the sling fabric is smooth underneath the thighs of the patient.

5. Attach the transport/transfer sling to the stand up lift. Refer to Attaching the Sling to the Stand Up Lift on page 20.

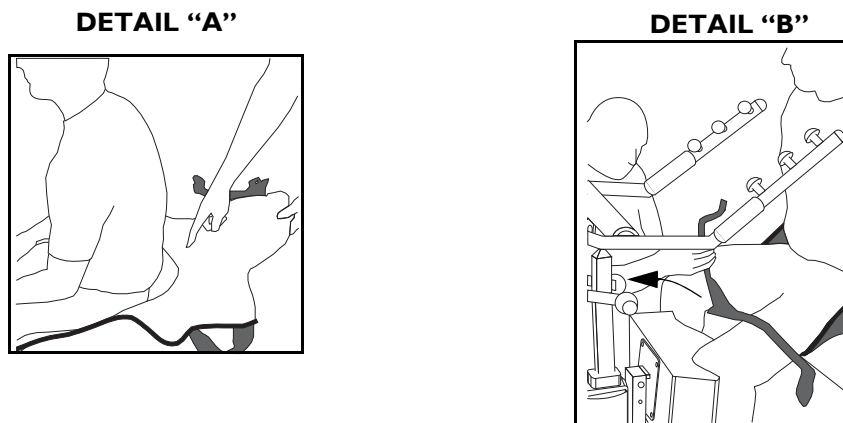

FIGURE 6.2 Positioning the Slings Around the Patient - Transport or Transfer Sling

Attaching the Sling to the Stand Up Lift

Standing Sling

NOTE: For this procedure, refer to FIGURE 6.3.

1. Determine the best attachment point for the sling on each lift arm. Use the following chart as a guideline to determine attachment point. Refer to Detail "A".

NOTE: The following chart is for reference ONLY.

ATTACHMENT POINT	PATIENT HEIGHT RANGE
Short	under 5 ft 6 in.
Medium	5 ft 6 in. to 5 ft 10 in.
Tall	over 5 ft 10 in.

⚠ WARNING

ALWAYS use the color coded strap on the standing sling closest to the patient while still maintaining patient stability and comfort.

Make sure the color coded strap sits flush against the attachment knob in Detail "B", otherwise injury or damage can result.

NOTE: The color coded straps can be used to place the patient in various positions. The colors make it easy to connect both sides of the sling equally.

2. From the outside of the stand up lift, attach the sling to the stand up lift at the attachment point determined in STEP 1. Refer to Detail "A".

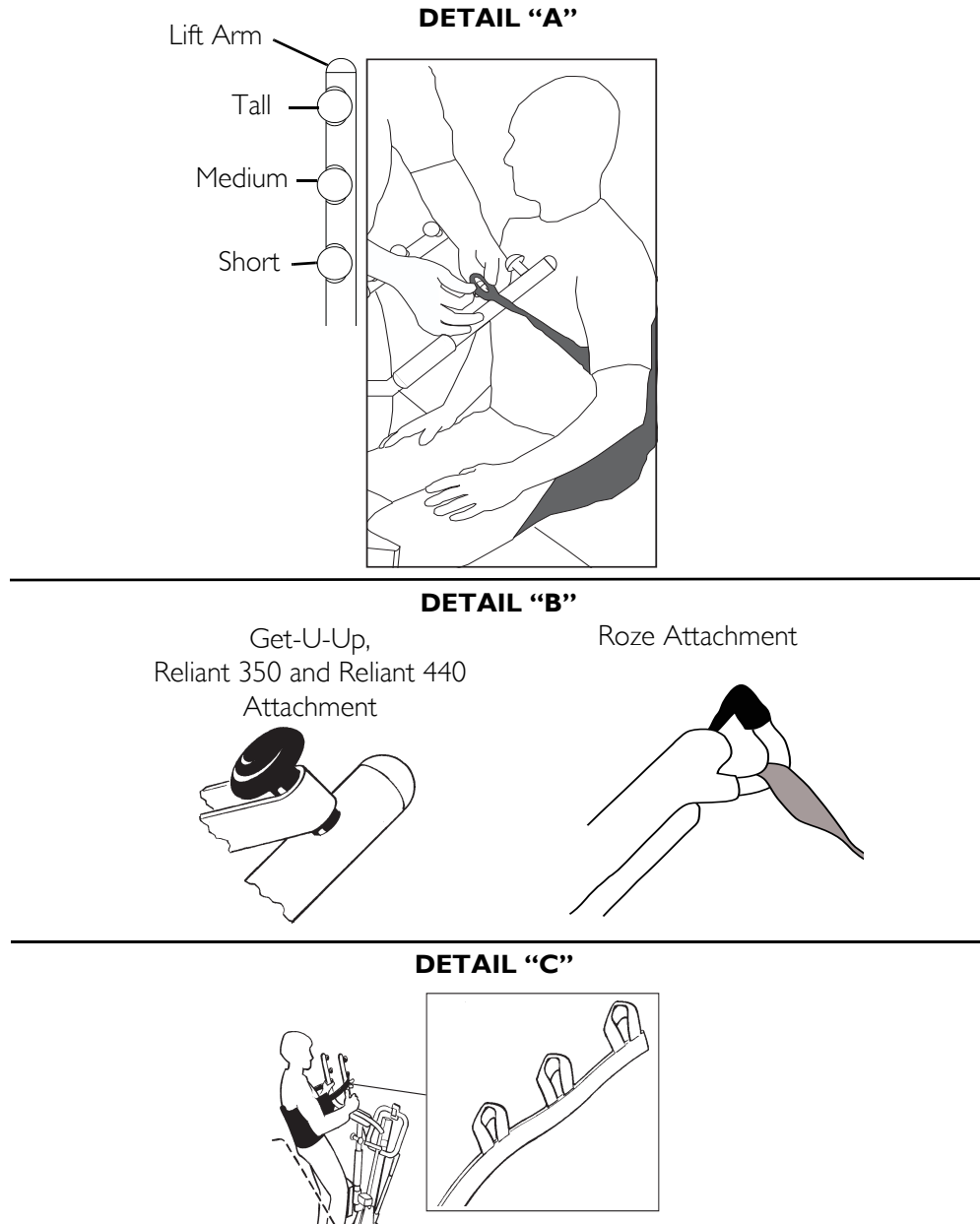

FIGURE 6.3 Attaching the Slings to the Stand Up Lift - Standing Sling

3. Make sure of the following:

- The sling is wrapped around the outside of each lift arm.
- The closest color coded strap to the patient is used to maintain stability and comfort.
- Get-U-UP, Reliant 350 and Reliant 440 - The color coded strap sits flush against the attachment knob. Refer to Detail "B". Roze - The color coded strap is fully seated on the attachment hook. Refer to Detail "B".
- The same color coded strap is used on each side of the standing sling. Refer to Detail "C".
- The same attachment point is used on each lift arm.

NOTE: If necessary, adjust the attachment point of the transport sling to each lift arm.

4. Once a stable and comfortable position is found for the patient, mark the attachment points and color coded strap used in the patient file for future use.
5. Transfer the patient. Refer to Transferring the Patient in the Patient Lift Owner's Manual.

Transport Sling or Transfer Sling

NOTE: For this procedure, refer to FIGURE 6.4 and FIGURE 6.5 on page 23.

1. Determine the best attachment point for the sling on each lift arm. Use the following chart as a guideline to determine attachment point. Refer to Detail "A".

NOTE: The following chart is for reference ONLY.

⚠ WARNING

ALWAYS use the color coded strap on the sling closest to the patient while still maintaining patient stability and comfort.

Make sure the color coded strap sits flush against the attachment knob in Detail "A" of FIGURE 6.5 on page 23, otherwise injury or damage can result.

NOTE: The color coded straps can be used to place the patient in various positions. The colors make it easy to connect both sides of the sling equally.

2. Pull the thigh supports forward and attach to the lower attachment points just above the pivoting knee pad.
3. Attach the top portion of the sling to each lift arm at the attachment point determined in STEP 1.

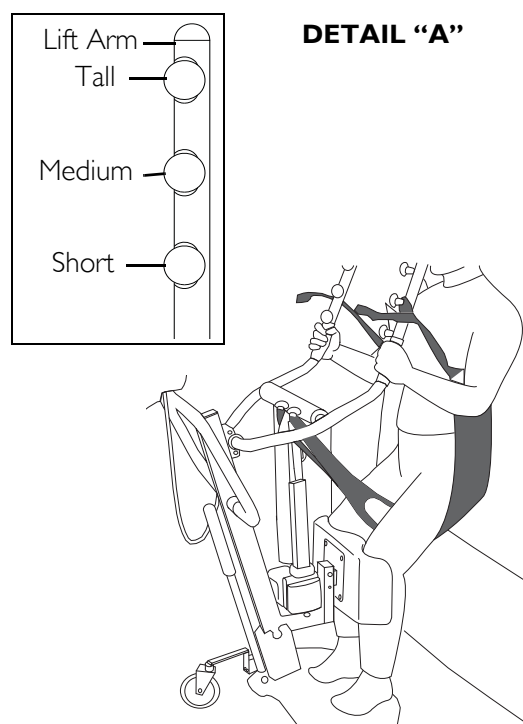

FIGURE 6.4 Attaching Slings to the Stand Up Lift - Transport Slings

4. Make sure of the following:

- The sling is wrapped around the outside of each lift arm.
- The closest color coded strap to the patient is used to maintain stability and comfort.
- The colored coded strap sits flush against the attachment knob.
- The same top color coded strap is used on each side of the sling.
- The same attachment point is used on each lift arm.
- The same bottom color coded strap is used on each side of the sling. Refer to Detail “B” of FIGURE 6.5.

NOTE: The top and bottom colored straps do not have to be the same.

NOTE: If necessary, adjust the attachment point of the sling to each lift arm.

5. Once a stable and comfortable position is found for the patient, mark the attachment points and color coded strap used in the patient file for future use.
6. Transfer patient. Refer to Transferring a Patient in the Stand Up Lift Owner's Manual.

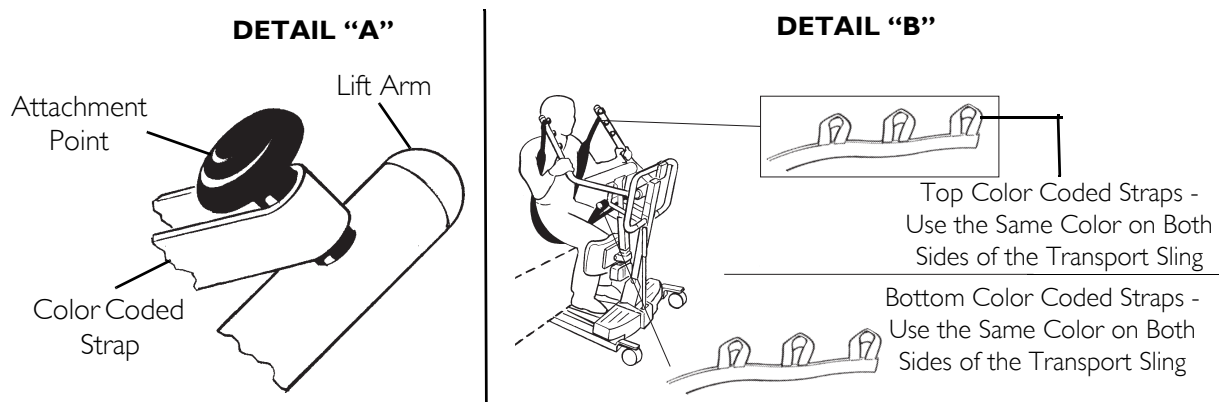

FIGURE 6.5 Attaching Slings to the Stand Up Lift - Transport or Transfer Slings

LIMITED WARRANTY

PLEASE NOTE: THE WARRANTY BELOW HAS BEEN DRAFTED TO COMPLY WITH FEDERAL LAW APPLICABLE TO PRODUCTS MANUFACTURED AFTER JULY 4, 1975.

This warranty is extended only to the original purchaser/user of our products.

This warranty gives you specific legal rights and you may also have other legal rights which vary from state to state.

Invacare warrants the products manufactured to be free from defects in materials and workmanship for a period of one year from the date of purchase. If within such warranty period any such product shall be proven to be defective, such product shall be repaired or replaced, at Invacare's option. This warranty does not include any labor or shipping charges incurred in replacement part installation or repair of any such product. Invacare's sole obligation and your exclusive remedy under this warranty shall be limited to such repair and/or replacement.

For warranty service, please contact the dealer from whom you purchased your Invacare product. In the event you do not receive satisfactory warranty service, please write directly to Invacare at the address on the back cover, provide dealer's name, address, date of purchase, indicate nature of the defect.

Invacare Corporation will issue a serialized return authorization. The defective unit or parts **MUST** be returned for warranty inspection using the serial number, when applicable as identification within 30 days of return authorization date. **DO NOT** return products to our factory without our prior consent. C.O.D. shipments will be refused; please prepay shipping charges.

LIMITATIONS AND EXCLUSIONS: THE FOREGOING WARRANTY SHALL NOT APPLY TO SERIAL NUMBERED PRODUCTS IF THE SERIAL NUMBER HAS BEEN REMOVED OR DEFACED, PRODUCTS SUBJECTED TO NEGLIGENCE, ACCIDENT, IMPROPER OPERATION, MAINTENANCE OR STORAGE, PRODUCTS MODIFIED WITHOUT INVACARE'S EXPRESS WRITTEN CONSENT (INCLUDING, BUT NOT LIMITED TO, MODIFICATION THROUGH THE USE OF UNAUTHORIZED PARTS OR ATTACHMENTS; PRODUCTS DAMAGED BY REASON OF REPAIRS MADE TO ANY COMPONENT WITHOUT THE SPECIFIC CONSENT OF INVACARE, OR TO A PRODUCT DAMAGED BY CIRCUMSTANCES BEYOND INVACARE'S CONTROL, AND SUCH EVALUATION WILL BE SOLELY DETERMINED BY INVACARE. THE WARRANTY SHALL NOT APPLY TO PROBLEMS ARISING FROM NORMAL WEAR OR FAILURE TO ADHERE TO THE INSTRUCTIONS IN THIS MANUAL.

THE FOREGOING WARRANTY IS EXCLUSIVE AND IN LIEU OF ANY OTHER EXPRESS WARRANTIES. IMPLIED WARRANTIES, IF ANY, INCLUDING THE IMPLIED WARRANTIES OF MERCHANTABILITY AND FITNESS FOR A PARTICULAR PURPOSE, SHALL NOT EXTEND BEYOND THE DURATION OF THE EXPRESSED WARRANTY PROVIDED HEREIN AND THE REMEDY FOR VIOLATIONS OF ANY IMPLIED WARRANTY SHALL BE LIMITED TO REPAIR OR REPLACEMENT OF THE DEFECTIVE PRODUCT PURSUANT TO THE TERMS CONTAINED HEREIN. INVACARE SHALL NOT BE LIABLE FOR ANY CONSEQUENTIAL OR INCIDENTAL DAMAGES WHATSOEVER.

SOME STATES DO NOT ALLOW EXCLUSION OR LIMITATION OF INCIDENTAL OR CONSEQUENTIAL DAMAGE, OR LIMITATION ON HOW LONG AN IMPLIED WARRANTY LASTS, SO THE ABOVE EXCLUSIONS AND LIMITATIONS MAY NOT APPLY TO YOU.

THIS WARRANTY SHALL BE EXTENDED TO COMPLY WITH STATE OR PROVINCIAL LAWS AND REQUIREMENTS.